



(19) **United States**

(12) **Patent Application Publication**
Kim et al.

(10) **Pub. No.: US 2010/0117937 A1**
(43) **Pub. Date: May 13, 2010**

(54) **ORGANIC ELECTRO-LUMINESCENT DISPLAY DEVICE**

(30) **Foreign Application Priority Data**

Nov. 12, 2008 (KR) 10-2008-0112410

(76) Inventors: **Hak Su Kim**, Seoul (KR); **Kyoung Don Woo**, Gumi-si (KR); **Young Jun Hong**, Gumi-si (KR)

Publication Classification

(51) **Int. Cl.**
G09G 3/30 (2006.01)

(52) **U.S. Cl.** **345/76**

(57) **ABSTRACT**

An OLED device is disclosed. The OLED device disposes a voltage divider and a switch unit in the output stage of a power supplier, thereby lowering the level of a supply voltage VDD, which is applied to a driver IC in an emission interval, below that of the supply voltage which is applied to the driver IC in a non-emission interval. Accordingly, the OLED device can reduce electric power consumption.

Correspondence Address:
BRINKS HOFER GILSON & LIONE
P.O. BOX 10395
CHICAGO, IL 60610 (US)

(21) Appl. No.: **12/579,749**

(22) Filed: **Oct. 15, 2009**

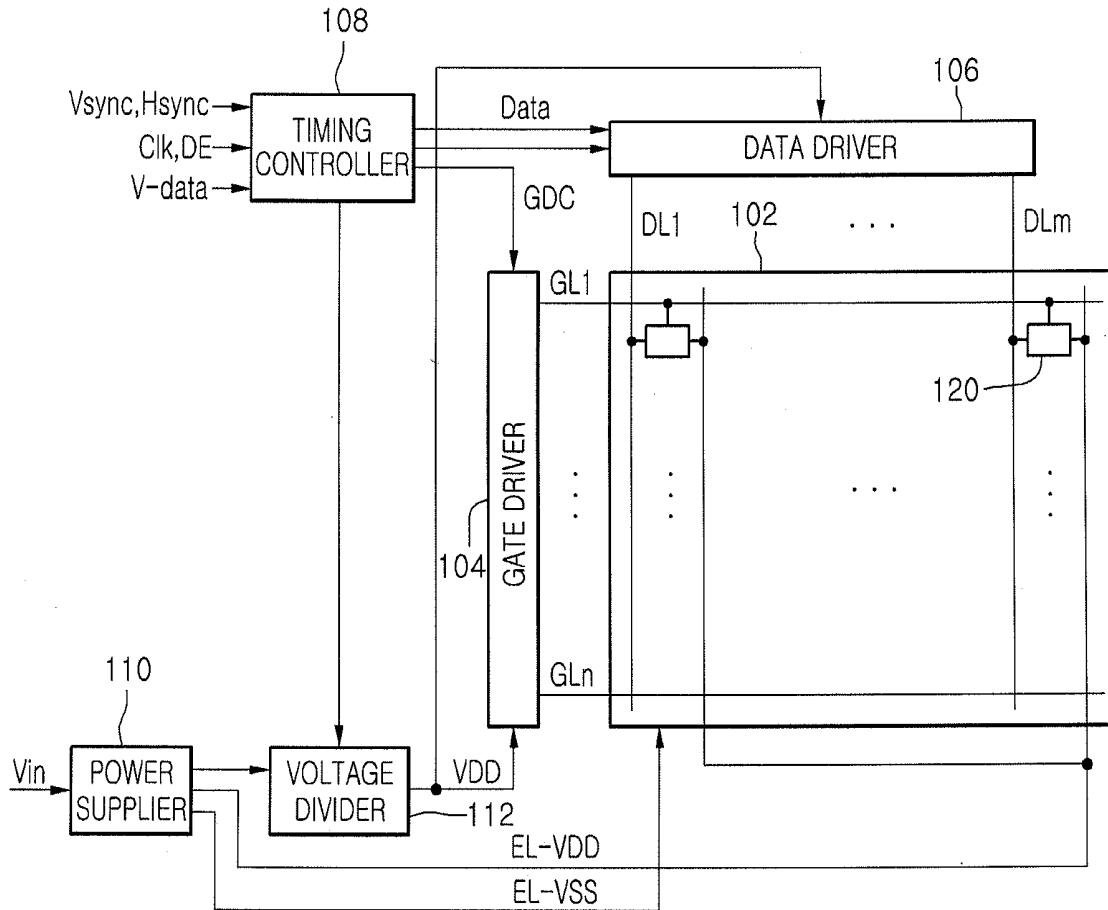

FIG. 1

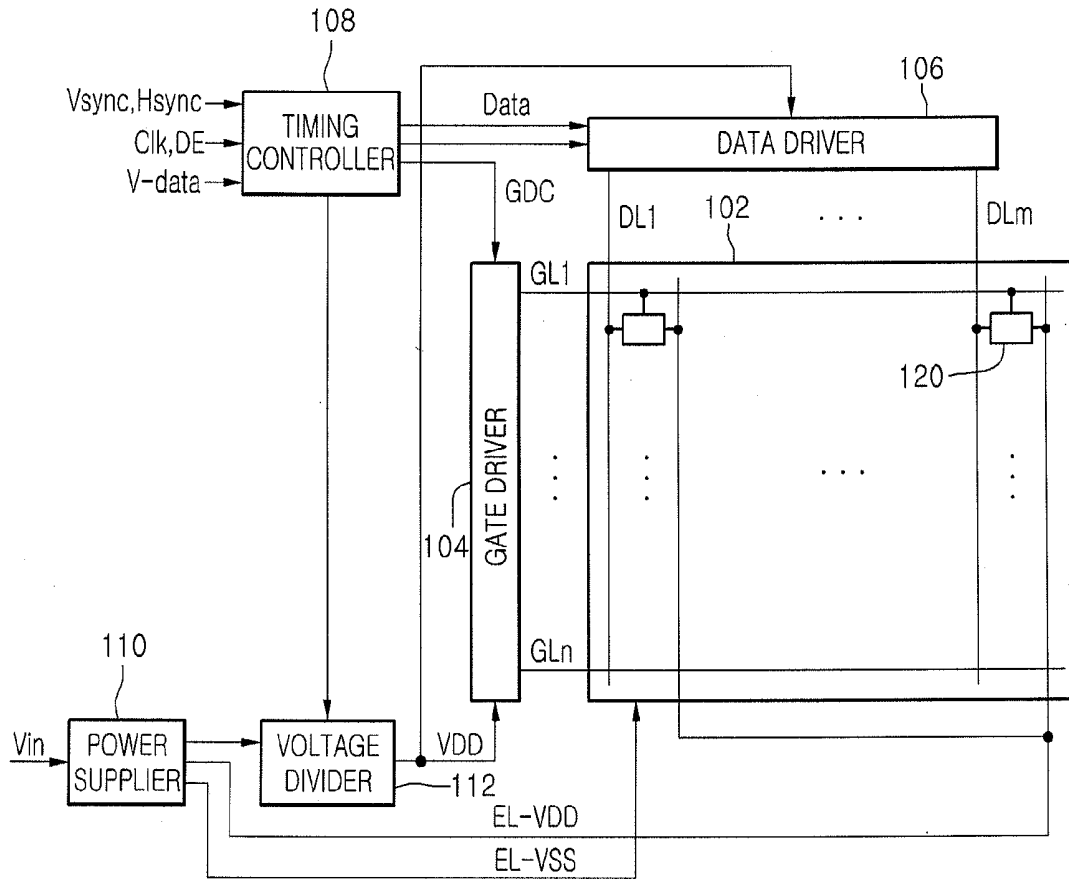

FIG. 2

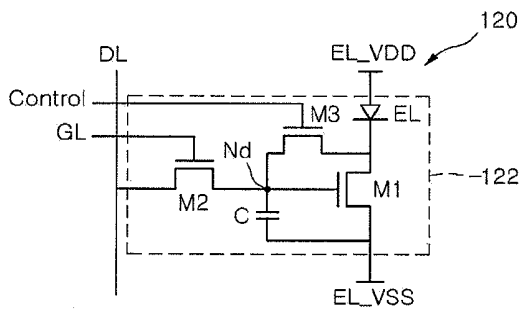

FIG. 3

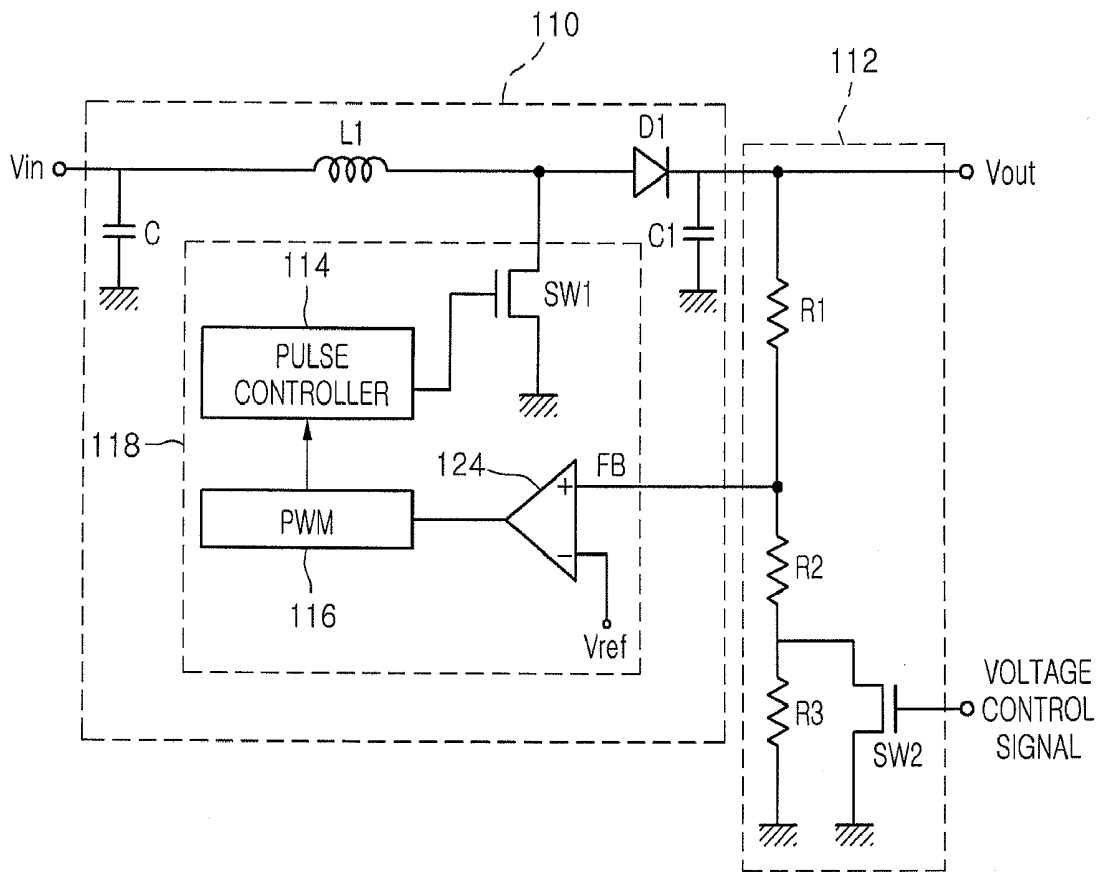
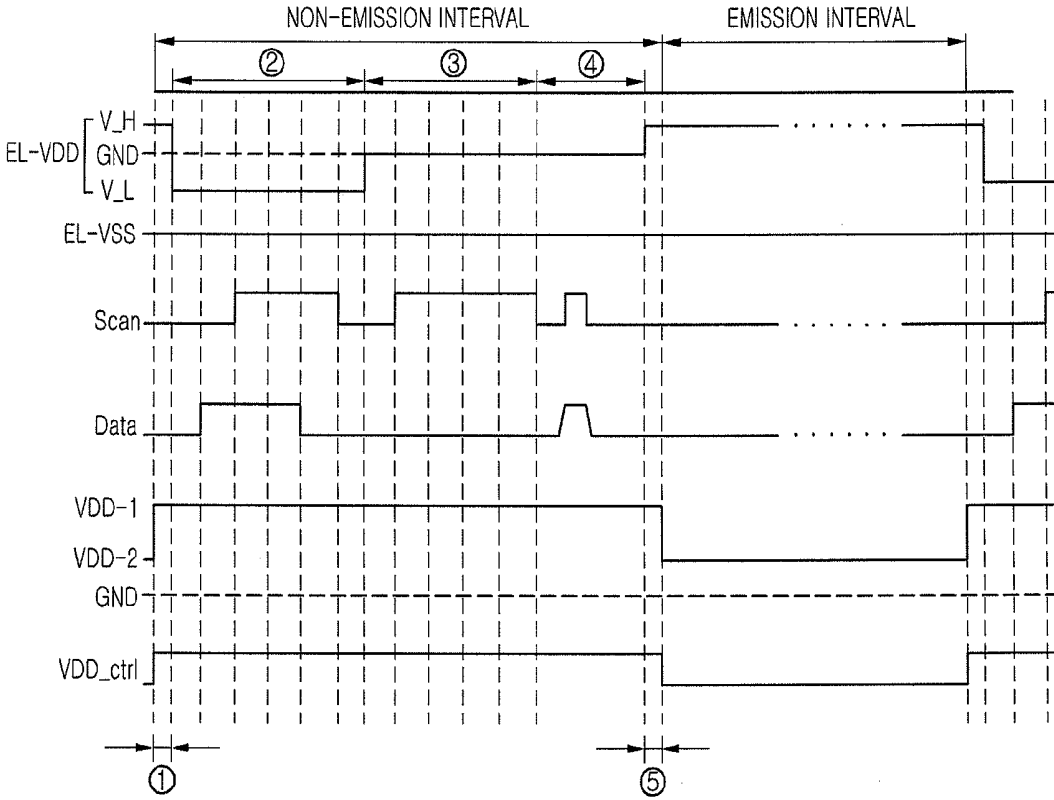

FIG. 4



ORGANIC ELECTRO-LUMINESCENT DISPLAY DEVICE

[0001] This application claims the benefit of Korea Patent Application No. 10-2008-0112410 filed on Nov. 12, 2008, the entire contents of which is incorporated herein by reference for all purposes as if fully set forth herein.

BACKGROUND

[0002] 1. Field of the Invention

[0003] This disclosure relates to an organic electro-luminescence display device adapted to reduce electric power consumption by lowering the level of a supply voltage VDD, which is applied to a driver IC (integrated circuit) in an emission interval, below that of the supply voltage which is applied to the driver IC in a non-emission interval.

[0004] 2. Discussion of the Related Art

[0005] As the information society grows, display devices capable of displaying information have been widely developed. These display devices include liquid crystal display (LCD) devices, organic electro-luminescence display (OLED) devices, plasma display devices, and field emission display devices.

[0006] Among the above display devices, OLED devices are self-luminescent display devices which electrically excite a fluorescent organic-compound to emit light. Such OLED devices have several desirable features such as a low driving voltage, a thin size, and so on. Moreover, OLED devices have a wide viewing angle and a fast response time, both of which prevent the disadvantages found in LED devices. In view of these points, OLED devices have received a significant amount of attention as next-generation display devices.

[0007] An OLED device includes a plurality of pixels arranged in a matrix. Each of the pixels includes a switching transistor, a storage capacitor, a drive transistor, and an organic light emission diode (OLED).

[0008] A data voltage is applied to the drive transistor by a switching operation of the switching transistor. The drive transistor derives a driving electric current from the data voltage. The OLED emits light corresponding to the driving electric current. The storage capacitor maintains the data voltage during one frame period. The switching transistor and the drive transistor are elements which increase the quantity of electric current as the temperature rises. The OLED is an element which emits light in proportion to a quantity of electric current received.

[0009] The OLED device is divided into a panel displaying an image and a driving portion for driving the panel. The driving portion includes a gate driver for driving a plurality of gate lines arranged on the panel, and a data driver for driving a plurality of data lines arranged on the panel. The driving portion can further include a timing controller for controlling the timing of both the gate driver and the data driver. Also, the driving portion can include a power supplier which generates a supply voltage VDD using an input voltage applied from an external power supply unit. The supply voltage VDD is used to drive the gate driver, the data driver, and the timing controller.

[0010] The supply voltage VDD generated in the power supplier usually maintains a constant level regardless of whether the OLED device is in an emitting interval or a non-emitting interval. Due to this, the electric power consumption of the power supplier increases. Furthermore, the

electric power consumption of the OLED device which includes this power supplier increases.

BRIEF SUMMARY

[0011] According to one aspect, an OLED device includes: a panel configured to include an electroluminescent element; a driver configured to drive the panel; a timing controller configured to control the timing of the driver; a power supplier configured to generate a supply voltage for driving the electroluminescent element and a main supply voltage for driving the driver, from an input voltage applied from an external power supply unit; and a voltage divider configured to respond to a voltage control signal applied from the timing controller and to vary the level of the main supply voltage applied from the power supplier to the driver according to emission and non-emission intervals of the luminescent element.

[0012] An OLED device according to another aspect embodiment includes: a panel configured to include an electroluminescent element; a driver configured to drive the panel; a timing controller configured to control the timing of the driver; a power supplier configured to generate a supply voltage for driving the electroluminescent element and a main supply voltage for driving the driver, from an input voltage applied from an external power supply unit; a switching element configured to be turned on in the non-emission interval of the electroluminescent element and turned off in the emission interval of the electroluminescent element, by the voltage control signal from the timing controller; and first to third resistors connected to differently divide the main supply voltage generated in the power supplier according to the turning on/off of the switching element so that the main supply voltage has a first voltage level in the non-emission interval of the electroluminescent element and a second voltage level lower than the first voltage level in the emission interval of the electroluminescent element. The first resistor includes one electrode connected to an output terminal of the power supplier and the other electrode connected to a first node between the second resistor and a feedback terminal of the power supplier. The second resistor includes one electrode connected to the first node and the other electrode connected to a second node to which the switching element and the third resistor are commonly connected. The third resistor includes one electrode connected to the second node and the other electrode connected to a ground source.

BRIEF DESCRIPTION OF THE DRAWINGS

[0013] The accompanying drawings, which are included to provide a further understanding of the embodiments and are incorporated in and constitute a part of this application, illustrate embodiment(s) of the invention and together with the description serve to explain the disclosure. In the drawings:

[0014] FIG. 1 is a schematic diagram showing an LCD device according to an embodiment of the present disclosure;

[0015] FIG. 2 is a circuit diagram showing in detail the pixel shown in FIG. 1;

[0016] FIG. 3 is a circuit diagram showing in detail the power supplier and the voltage divider shown in FIG. 1; and

[0017] FIG. 4 is a timing chart explaining the driving timing of the OLED device shown in FIG. 1.

DETAILED DESCRIPTION OF THE DRAWINGS AND THE PRESENTLY PREFERRED EMBODIMENTS

[0018] Reference will now be made in detail to the embodiments of the present disclosure, examples of which are illus-

trated in the accompanying drawings. These embodiments introduced hereinafter are provided as examples in order to convey their spirits to the ordinary skilled person in the art. Therefore, these embodiments might be embodied in a different shape, so are not limited to these embodiments described here. Also, the size and thickness of the device might be expressed to be exaggerated for the sake of convenience in the drawings. Wherever possible, the same reference numbers will be used throughout this disclosure including the drawings to refer to the same or like parts.

[0019] FIG. 1 is a schematic diagram showing an LCD device according to an embodiment of the present disclosure. Referring to FIG. 1, an OLED device according to an embodiment of the present disclosure includes a panel **102** configured to include a plurality of gate lines $GL1 \sim GLn$ and a plurality of data lines $DL1 \sim DLm$ arranged to display an image, a gate driver **104** configured to apply scan signals to the plural gate lines $GL1 \sim GLn$, a data driver **106** configured to apply data signals to the plural data lines $DL1 \sim DLm$, and a timing controller **108** configured to control the timing of the gate driver **104** and the data driver **106**.

[0020] The OLED device of the present embodiment further includes a power supplier **110** configured to generate a supply voltage VDD using an input voltage applied from an external power supply unit (not shown), and a voltage divider **112** configured to vary the level of the supply voltage VDD generated in the power supplier **110** according to emission or non-emission intervals. The supply voltage VDD is used to drive the gate driver **104** and the data driver **106**.

[0021] The plural gate lines $GL1 \sim GLn$ and the plural data lines $DL1 \sim DLm$ arranged on the panel **102** cross each other perpendicularly and define pixels **120**. Each of the pixels **120** includes an electroluminescent element EL and a pixel circuit **122** configured to control the electroluminescent element EL , as shown in FIG. 2. The pixels **120** are connected to supply lines to which first and second supply voltages EL_VDD and EL_VSS for the electroluminescent element EL are applied. The pixels **120** respond to the scan signals transferred through the respective gate lines and the data signals transferred through the respective data lines DL , thereby emitting lights.

[0022] The electroluminescent element EL of the pixel **120** includes an organic thin film (not shown) and first and second electrodes (not shown) formed on both sides of the organic thin film. The first electrode is formed of a metal material and is used as an anode electrode. The second electrode is formed of a transparent conductive material and is used as a cathode electrode. The second electrodes of the electroluminescent elements EL can be connected to one another.

[0023] The pixel circuit **122** includes first to third transistors $M1 \sim M3$ and a capacitor C . Such components included in the pixel circuit **122** can be modified in a variety of manners.

[0024] The second transistor $M2$ includes a gate electrode connected to the respective gate line GL , a source electrode connected to the respective data line DL , and a drain electrode which, together with a first electrode of the capacitor C , a gate electrode of the first transistor $M1$, and a source electrode of the third transistor $M3$, is connected to a node Nd . Such a second transistor $M2$ responds to the scan signal applied from the respective gate line GL and samples the data signal applied from the respective data line DL .

[0025] The capacitor C includes the first electrode connected to the node Nd and a second electrode a second supply line transferring the second supply voltage EL_VSS for the electroluminescent EL . The capacitor C charges a voltage

corresponding to the data signal transferred through the respective data line DL while the second transistor $M2$ is turned on (or activated). The capacitor C maintains a voltage difference between the gate and source electrodes of the first transistor $M1$ using its charged voltage.

[0026] The first transistor $M1$ includes the gate electrode connected to the node Nd , the source electrode commonly connected to the cathode electrode of the electroluminescent element EL and a drain electrode of the third transistor $M3$, and a drain electrode commonly connected to the second electrode of the capacitor C and the second supply line for transferring the second supply voltage EL_VSS for the electroluminescent element EL . The first transistor $M1$ functions as a source of electric current, applying an electric current to the electroluminescent element EL . In other words, the first transistor $M1$ controls the quantity of electric current flowing through the electroluminescent element EL by the charged voltage which is applied from the capacitor C to its gate electrode.

[0027] The third transistor $M3$ includes a gate electrode connected to a control line receiving a control signal "Control", the source electrode connected to the node Nd , and the drain electrode commonly connected to the source electrode of the first transistor $M1$ and the cathode electrode of the electroluminescent element EL . The third transistor $M3$ is used for sensing (or detecting) the threshold voltage V_{th} of the first transistor $M1$. During the detection of the threshold voltage, the third transistor $M3$ is in a connection state such that the first transistor $M1$ functions as a diode.

[0028] The gate driver **104** generates the scan signal and sequentially applies the scan signal to the plural gate lines $GL1 \sim GLn$. Accordingly, the pixels connected to the gate lines $GL1 \sim GLn$ are sequentially selected in one horizontal line.

[0029] The data driver **106** applies the data signals to the plural data lines $DL1 \sim DLm$ whenever the scan signal is applied to any one of the gate lines $GL1 \sim GLn$, so that the data signals are transferred to the pixels on the respective horizontal line. The data driver **106** may be implemented in a current driving system. Alternatively, the data driver **106** can be configured in a number of different driving systems according to the pixel circuit **122**.

[0030] The timing controller **108** receives synchronous signals V_{sync} and H_{sync} , a data enable signal DE , a clock signal CLK , and image data V -data from an external system (not shown) such as the graphic module of a computer system or the image demodulating module of a television receiver. The timing controller **108** generates gate control signals GCS and data control signals DCS using the synchronous signals V_{sync} and H_{sync} , the data enable signal DE , and the clock signal CLK from the external system. The gate control signals are used to control the gate driver **104**, and the data control signals are used to control the data driver **106**. Also, the timing controller **108** rearranges the image data V -data from the external system into the data format required by the panel **102** and applies the rearranged data "Data" to the data driver **106**.

[0031] The power supplier **110** generates the first and second supply voltages EL_VDD and EL_VSS for the electroluminescent element EL using an input voltage V_{in} applied from an external power supply unit (not shown). Also, the power supplier **110** generates a main supply voltage VDD which is used to drive driver ICs such as the gate driver **104**, the data driver **106**, and so on.

[0032] The timing of the voltage divider **112** is controlled by the timing controller **108**, which changes the level of the

main supply voltage VDD according to emission or non-emission intervals of the electroluminescent element EL. The level-changed main supply voltage is then applied to the gate driver **104** and the data driver **106**.

[0033] FIG. **3** is a circuit diagram showing in detail the power supplier and the voltage divider shown in FIG. **1**. As shown in FIGS. **1** and **3**, the power supplier **110** includes: an inductor **L1** configured to receive the input voltage V_{in} from the external power supply unit and to temporarily store an electric current corresponding to the input voltage V_{in} ; an output controller **118** configured to form a current path together with the inductor **L1** and to control the output period of a voltage corresponding to the stored electric current of the inductor **L1**; and a capacitor **C1** configured to charge the voltage corresponding to the stored electric current of the inductor **L1**.

[0034] The power supplier **110**, as described above, uses the input voltage V_{in} applied from the external power supply unit and generates the first and second supply voltages EL_VDD and EL_VSS , allowing the electroluminescent element **EL** to emit light, as well as the main supply voltage **VDD**. However, for the convenience of explanation, only part of the power supplier **110** (i.e., the circuit portion for generating the main supply voltage **VDD** to be applied to the driver ICs such as the gate driver **104** and data driver **106**) will be described in the OLED device of the present embodiment.

[0035] The output controller **118** includes a pulse controller **114** configured to generate pulses of a fixed frequency, a pulse width modulator (PWM) **116** configured to modulate the width of the pulse to be generated in the pulse controller **114**, and a first switching element **SW1** alternately turned on and off according to the pulse which is generated in the pulse controller **114**. Also, the output controller **118** can further include a comparator **124**.

[0036] The pulse controller **114** generates pulses having a fixed frequency upon the control of the PWM **116** and applies these pulses to the first switching element **SW1**. The first switching element **SW1** is turned on or off according to a high or low logic state of the pulse generated in the pulse controller **114**.

[0037] When the first switching element **SW1** is turned off, the current path of the inductor **L1** of the power supplier **110** is broken with the output controller **118** and a current path is formed between the inductor **L1** and the capacitor **C1**. As such, the capacitor **C1** charges a voltage corresponding to the electric current stored in the inductor **L1**. In other words, an arbitrary voltage is charged in the capacitor when the first switching element **SW1** is turned off. The voltage charged in the capacitor **C1** is applied the voltage divider **112**.

[0038] If the first switching element **SW1** is turned on (activated), the inductor **L1** is connected to the output controller **118** and forms a current path with the first switching element **SW1** of the output controller **118**. Accordingly, the electric current stored in the inductor is applied to the first switching element **SW1** which has one electrode which is grounded to a ground source **GND**.

[0039] The voltage divider **112** is configured to include first to third resistors **R1~R3** and a second switching element **SW2**. The first resistor **R1** has the highest resistance among the resistors **R1~R3**. The second switching element **SW2** responds to a voltage control signal generated in the timing controller **108** and is turned on or off. The second switching element **SW2** is configured to include a NMOS transistor. In this case, the voltage control signal has a high logic value in

the non-emission interval, when the electroluminescent element **EL** of FIG. **2** does not emit light. Also, the voltage control signal maintains a low logic value in the emission interval, i.e., when the electroluminescent element **EL** emits light.

[0040] The level of the voltage charged in the capacitor **C1** varies between the activation/deactivation of the second switching element **SW2**, i.e., the connection configuration of the first to third resistors **R1~R3** of the voltage divider **112**.

[0041] If the voltage control signal generated in the timing controller **108** is high, i.e., in the case of the non-emission interval, the second switching element **SW2** of the voltage divider **112** is turned on and allows the charged voltage of the capacitor **C1** to be divided by the first and second resistors **R1** and **R2**. The divided voltage is feedback to the power supplier **110** and forces an output voltage V_{out} (i.e., the main supply voltage **VDD**) to rise to a first main supply voltage **VDD_1**. The first main supply voltage **VDD_1** is applied to the gate and data drivers **104** and **106** of FIG. **1** and allows the gate and data drivers to be driven in the non-emission interval of the electroluminescent element **EL**.

[0042] On the hand, when the voltage control signal generated in the timing controller **108** is low, i.e., in the case of the emission interval, the second switching element **SW2** of the voltage divider **112** is turned off and allows the charged voltage of the capacitor **C1** to be divided by the first to third resistors **R1** to **R3**. The divided voltage is feedback to the power supplier **110** and forces the output voltage V_{out} (i.e., the main supply voltage **VDD**) to be lowered at a second main supply voltage **VDD_2**. The second main supply voltage **VDD_2** is applied to the gate and data drivers **104** and **106** of FIG. **1** and allows the gate and data drivers to be driven in the emission interval of the electroluminescent element **EL**. The second main supply voltage **VDD_2** has a level lower than that of the first main supply voltage **VDD_1**.

[0043] The first and second resistors **R1** and **R2** are connected in parallel to one input terminal of the comparator **124** of the output controller **118**. As such, the comparator **124** receives the divided voltage from a node between the first and second resistors **R1** and **R2**. The comparator **124** compares the divided voltage from the node between the first and second resistors **R1** and **R2** with a reference voltage V_{ref} and applies a comparison signal in accordance with the compared resultant to the PWM **116**. The PWM **116** determines whether or not to enable the pulse controller **114** to modulate the width of the pulse, according to the logic value (i.e., the high or low logic value) of the comparison signal.

[0044] The power supplier **110** can further include a filter **C** disposed in its input stage, because it receives the input voltage V_{in} from an external power supply unit. The filter **C** eliminates noise which may be included in the input voltage V_{in} . Also, the power supplier **110** can include a diode **D1** connecting the inductor **L1** and the capacitor **C1**. The diode **D1** prevents the electric current stored in the inductor **L1** from flowing in a reverse direction.

[0045] In this manner, an arbitrary voltage corresponding to the electric current stored in the inductor **L1** is charged in the capacitor **C1** upon the control of the output controller **118** and the charged voltage of the capacitor **C1** is applied to the voltage divider **112**. The voltage divider **112** uses the first to third resistors **R1** to **R3** and derives the first or second main supply voltage **VDD_1** or **VDD_2** from the charged voltage of the capacitor **C1** in the non-emission or emission interval of the electroluminescent element **EL**. The voltage divider

112 applies the first or second main supply voltage VDD₁ or VDD₂ to the gate driver **104** and the data driver **106**.

[0046] FIG. 4 is a timing chart explaining the driving timing of the OLED device shown in FIG. 1. As shown in FIGS. 1 and 4, the voltage control signal VDD_{ctrl} has a high logic in the non-emission interval of the electroluminescent element EL and has a low logic in the emission interval of the electroluminescent element EL. The non-emission interval is roughly divided into first to fifth sub-intervals ①~⑤.

[0047] The scan signal "Scan" and the data signal "Data" shown in the timing chart of FIG. 4 change according to the configuration of the pixel of FIG. 2. As such, the scan signal "Scan" and the data signal "Data" are not limited to the waveforms shown in FIG. 4.

[0048] The first sub-interval ① of the non-emission interval corresponds to the falling period of the first supply voltage EL_VDD which is generated in the power supplier **110** and used to drive the electroluminescent element EL. In other words, the first sub-interval ① of the non-emission interval can be designated as a period which enables the first supply voltage for the electroluminescent element EL to change from a high level to a low level. In the first sub-interval ① of the non-emission interval, the driver ICs, such as the gate and data drivers **104** and **106** shown in FIG. 1, may be set up.

[0049] The second sub-interval ② of the non-emission interval can be designated as a period which forces the voltage charged in the capacitor C of the pixel **120** shown in FIG. 2 to be reset. As such, the second sub-interval ② of the non-emission interval may correspond to the period during which the first supply voltage EL_VDD for the electroluminescent element EL maintains a low level.

[0050] In the third sub-interval ③ of the non-emission interval, the first supply voltage EL_VDD for the electroluminescent element EL is grounded and the scan signal "Scan" of a high logic is applied to the gate line GL shown in FIG. 1. In other words, the third sub-interval ③ of the non-emission interval can be designated as a period sensing the threshold voltage V_{th} of the first transistor M1 included in the pixel **120** of FIG. 2.

[0051] In the fourth sub-interval ④ of the non-emission interval, the scan signal "Scan" maintaining a high logic during one horizontal period is applied to the gate line GL and the data signal "Data" is applied to the data line DL. At the same time, the first supply voltage EL_VDD for the electroluminescent element EL is still grounded. As such, the fourth sub-interval ④ of the non-emission interval can be designated as a period which charges the voltage of the data signal "Data" into the capacitor C of the pixel **120** shown in FIG. 2.

[0052] The first supply voltage EL_VDD for the electroluminescent element EL rises to a high level in the fifth sub-interval ⑤ of the non-emission interval. At the same time, the scan signal "Scan" of low logic is applied to the gate line GL, while no the data signal is applied to the data line DL.

[0053] On the other hand, the voltage control signal VDD_{ctrl} maintains the high logic in the first to fifth sub-intervals ①~⑤ of the non-emission interval. As such, the second switching element SW2 is turned on (or activated) and allows the first main supply voltage VDD₁ to be output from the voltage divider **112**. Accordingly, the gate driver **104** and the data driver **106** receive the first main supply voltage VDD₁ output from the voltage divider **112** in the non-emission interval.

[0054] The fifth sub-interval ⑤ of the non-emission interval can be designated as a period discharging the voltage

charged in the capacitor C1 of the power supplier **110**. The fifth sub-interval ⑤ of the non-emission interval allows the power supplier **110** and the voltage divider **112** to have enough time to generate the second main supply voltage VDD₂ before the electroluminescent element EL changes from the non-emission interval to the emission interval.

[0055] The voltage control signal VDD_{ctrl} has the low logic in the emission interval. Then, the first supply voltage EL_VDD for the electroluminescent element EL has the high level and enables the electroluminescent element EL to emit light. Also, the voltage divider **112** outputs the second main supply voltage VDD₂ to be applied to the gate driver **104** and the data driver **106**, in the emission interval.

[0056] The second main supply voltage VDD₂ has a level lower than the first main supply voltage VDD₁. In other words, the second main supply voltage VDD₂ is lower than the first main supply voltage VDD₁ and higher than the logic voltage (for example, V_{cc} of 2.8V) of the driver ICs such as the gate and data drivers **104** and **106**. Consequently, the second main supply voltage VDD₂ can be established at a minimized level, which allows the driver ICs such as the gate and data driver **104** and **106** to maintain their operating state, at a little more than the minimized level.

[0057] In this way, the first main supply voltage VDD₁ is applied to the driver ICs such as the gate and data drivers **104** and **106** in the non-emission interval of the electroluminescent element EL, while the second main supply voltage VDD₂ is applied to the driver ICs in the emission interval of the electroluminescent element EL. As such, the gate and data drivers **104** and **106** are normally driven by the first main supply voltage VDD₁ in the non-emission interval. Meanwhile, in the emission interval, the gate and data drivers **104** and **106** only maintain their operating state by the second main supply voltage VDD₂ which is lower than the first main supply voltage VDD₁ in voltage level.

[0058] As described above, the OLED device according to an embodiment of the present disclosure allows the driver ICs such as the gate and data drivers **104** and **106** to be driven by the second main supply voltage VDD₂ having a level lower than that of the first main supply voltage VDD₁, in the emission interval of the electroluminescent element EL. Accordingly, the OLED device can greatly reduce electric power consumption in comparison with the related art OLED device which allows the driver ICs to be driven by the first main supply voltage VDD₁ regardless of the emission and non-emission intervals.

[0059] Although the present disclosure has been limitedly explained regarding only the embodiments described above, it should be understood by the ordinary skilled person in the art that the present disclosure is not limited to these embodiments, but rather that various changes or modifications thereof are possible without departing from the spirit of the present disclosure. Accordingly, the scope of the present disclosure shall be determined only by the appended claims and their equivalents.

1. An organic electro-luminescence display device comprising:

- a panel configured to include an electroluminescent element;
- a driver configured to drive the panel;
- a timing controller configured to control the timing of the driver;
- a power supplier configured to generate a supply voltage that drives the electroluminescent element and a main

supply voltage that drives the driver, from an input voltage applied from an external power supply unit; and a voltage divider configured to respond to a voltage control signal applied from the timing controller and to vary the level of the main supply voltage applied from the power supplier to the driver according to emission and non-emission intervals of the luminescent element.

2. The organic electro-luminescence display device claimed as claim 1, wherein the voltage divider includes;

a switching element configured to be turned on by the voltage control signal from the timing controller in the non-emission interval of the electroluminescent element and turned off in the emission interval of the electroluminescent element; and

first to third resistors connected to differently divide the main supply voltage generated in the power supplier according to the turning on/off of the switching element so that the main supply voltage has a first voltage level in the non-emission interval of the electroluminescent element and a second voltage level lower than the first voltage level in the emission interval of the electroluminescent element,

wherein the first resistor includes one electrode connected to an output terminal of the power supplier and the other electrode connected to a first node between the second resistor and a feedback terminal of the power supplier; the second resistor includes one electrode connected to the first node and the other electrode connected to a second node to which the switching element and the third resistor are commonly connected; and the third resistor includes one electrode connected to the second node and the other electrode connected to a ground source.

3. The organic electro-luminescence display device claimed as claim 2, wherein the voltage divider divides the main supply voltage applied from the power supplier by the first and second resistors among the first to third resistors and allows the main supply voltage of the first voltage level to be applied to the driver, when the switching element is turned on.

4. The organic electro-luminescence display device claimed as claim 2, wherein the voltage divider divides the main supply voltage applied from the power supplier by the first to third resistors and allows the main supply voltage of

the second voltage level to be applied to the driver, when the switching element is turned off.

5. The organic electro-luminescence display device claimed as claim 2, wherein the switching element includes an NMOS transistor.

6. The organic electro-luminescence display device claimed as claim 2, wherein the first resistor has the largest resistance among the first to third resistors.

7. An organic electro-luminescence display device comprising:

a panel configured to include an electroluminescent element;

a driver configured to drive the panel;

a timing controller configured to control the timing of the driver;

a power supplier configured to generate a supply voltage for driving the electroluminescent element and a main supply voltage for driving the driver, from an input voltage applied from an external power supply unit;

a switching element configured to be turned on in the non-emission interval of the electroluminescent element and turned off in the emission interval of the electroluminescent element, by the voltage control signal from the timing controller; and

first to third resistors connected to differently divide the main supply voltage generated in the power supplier according to the turning on/off of the switching element so that the main supply voltage has a first voltage level in the non-emission interval of the electroluminescent element and a second voltage level lower than the first voltage level in the emission interval of the electroluminescent element,

wherein the first resistor includes one electrode connected to an output terminal of the power supplier and the other electrode connected to a first node between the second resistor and a feedback terminal of the power supplier; the second includes one electrode connected to the first node and the other electrode connected to a second node to which the switching element and the third resistor are commonly connected; and the third resistor includes one electrode connected to the second node and the other electrode connected to a ground source.

* * * * *

专利名称(译)	有机电致发光显示装置		
公开(公告)号	US20100117937A1	公开(公告)日	2010-05-13
申请号	US12/579749	申请日	2009-10-15
[标]申请(专利权)人(译)	金鹤SU WOO KYOUNG DON HONG YOUNG JUN		
申请(专利权)人(译)	金鹤SU WOO KYOUNG DON HONG YOUNG JUN		
当前申请(专利权)人(译)	金鹤SU WOO KYOUNG DON HONG YOUNG JUN		
[标]发明人	KIM HAK SU WOO KYOUNG DON HONG YOUNG JUN		
发明人	KIM, HAK SU WOO, KYOUNG DON HONG, YOUNG JUN		
IPC分类号	G09G3/30		
CPC分类号	G09G3/3233 G09G2300/0819 G09G2330/028 G09G2320/043 G09G2330/021 G09G2300/0842		
优先权	1020080112410 2008-11-12 KR		
其他公开文献	US8344974		
外部链接	Espacenet USPTO		

摘要(译)

公开了一种OLED器件。OLED器件在电源的输出级中设置分压器和开关单元，从而将在发光间隔中施加到驱动器IC的电源电压VDD的电平降低到低于电源电压的电平。在非发射间隔中应用于驱动器IC。因此，OLED器件可以减少电力消耗。

